

I

N

F

A

IN[formational] FA[cilitator]
monument to the first amendment

CONGRESS SHALL
RESPECTING AN
OF RELIGION, OR
FREE EXERCISE
ABRIDGING THE
SPEECH, OR OF T
THE RIGHT OF
PEACEABLY TO
TO PETITION TH
FOR A REDRESS

ALL MAKE NO LAW
ESTABLISHMENT
PROHIBITING THE
E THEREOF; OR
E FREEDOM OF
HE PRESS; OR OF
F THE PEOPLE
ASSEMBLE, AND
E GOVERNMENT
OF GRIEVANCES.

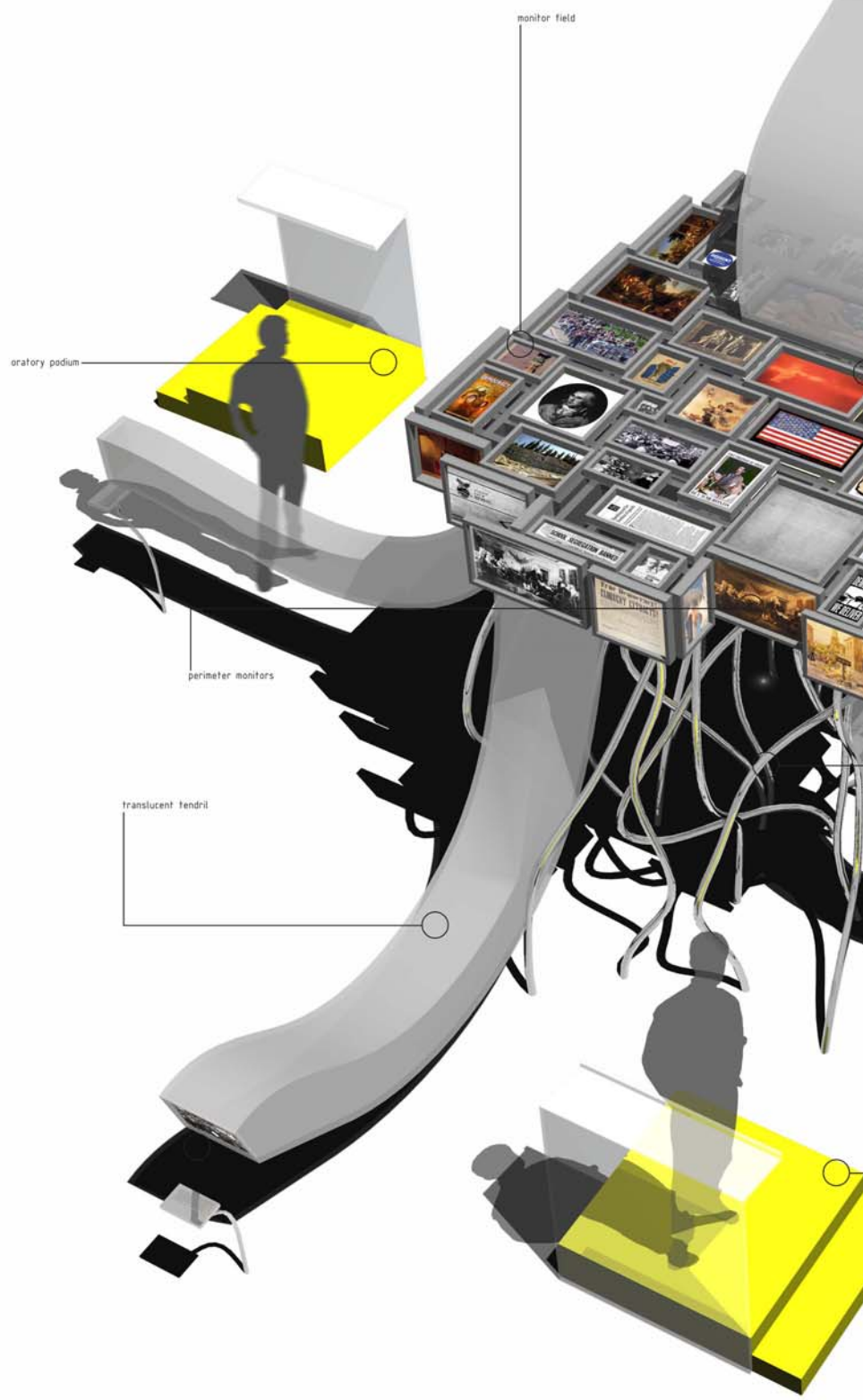

oratory podium

monitor field

perimeter monitors

translucent tendrils

e

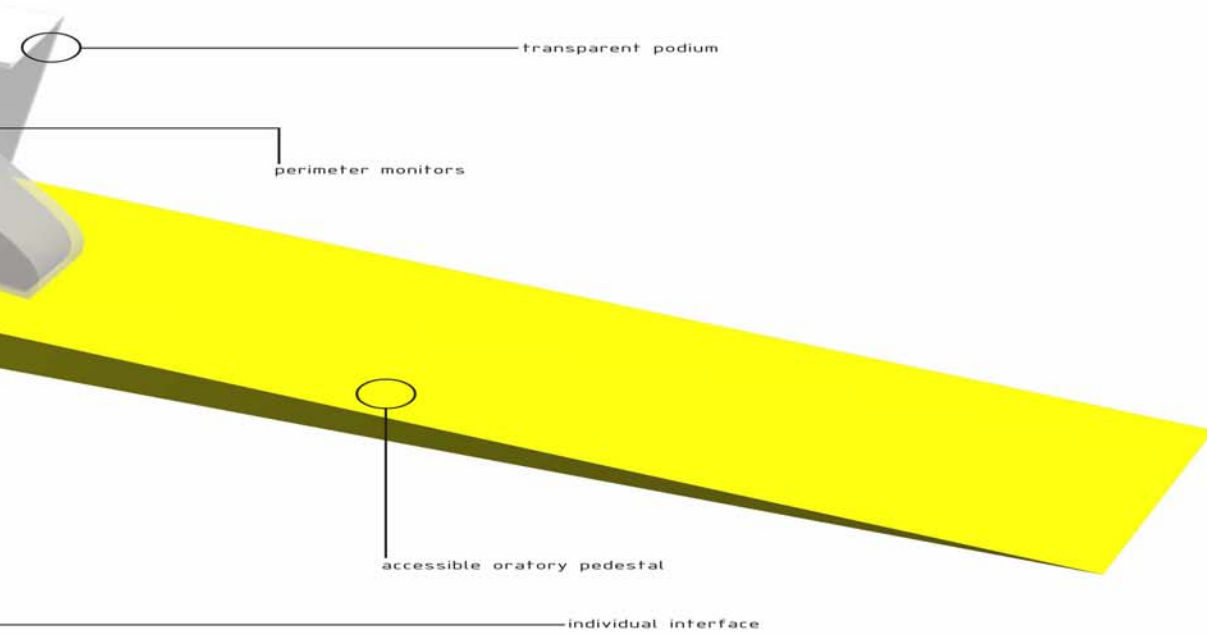

The foundation of democracy and freedom is information. The **INFA** serves as an informational facilitator. As a conglomeration of hovering monitors, the **INFA** serves as an informational outlet: a gateway to the Internet, the Chicago Tribune Archives, and a host of global digital databases. A collection of monitors scroll through programmed and randomized images on: The First Amendment, The Bill of Rights, The Constitution, and Democracy in all of its facets. Suspended on a dangling field of organic chrome columns, the monitors wrap all six sides of the irregularly formed cluster. Five of these monitors extrude off the main body: four tendrils fold down to service the main level while one tendrils folds up to service the second level of the rotunda. At the end of each tendrils is an individual access point [a monitor, mouse and keyboard] providing a direct link into the **INFA**. As one engages the machine, the information accessed is ingested by the **INFA** and included in its randomized dispersal of information across the rest of the image field. Three additional interfaces are located by the existing reception desk for a distanced engagement. Intermittently scattered around the perimeter of the **INFA** are three oratorical podiums for the production and distribution of discourse. Based upon the tradition of the soapbox, the elevated plateau allows for a seat of prominence to engage an audience and exercise the First Amendment. The **INFA** is not an object that merely commemorates, documents, and educates the viewer on the myriad facets and privileges of the first amendment [though it does this through the scrolling images (historical and contemporary) quilted on its surface], but rather serves as an instigator: providing the source material for individual belief and an infrastructure for the active engagement with The First Amendment.

information surfaces

stations

oratorical platforms

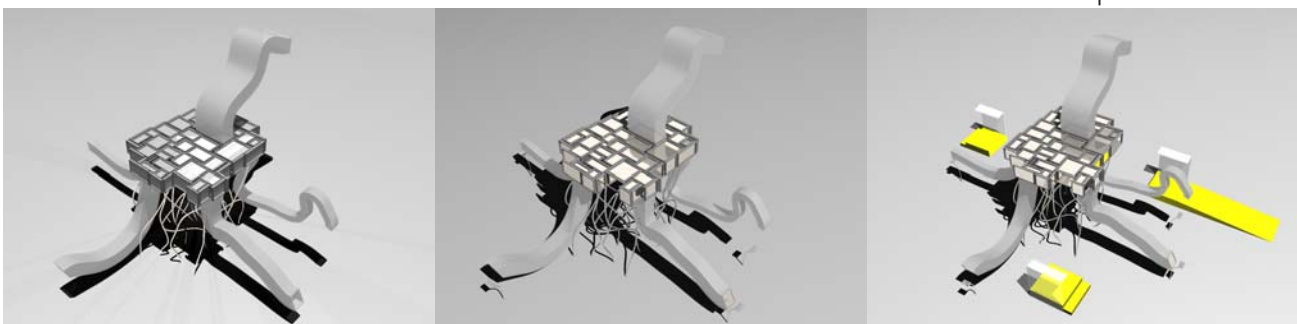

INFA sequences of interface

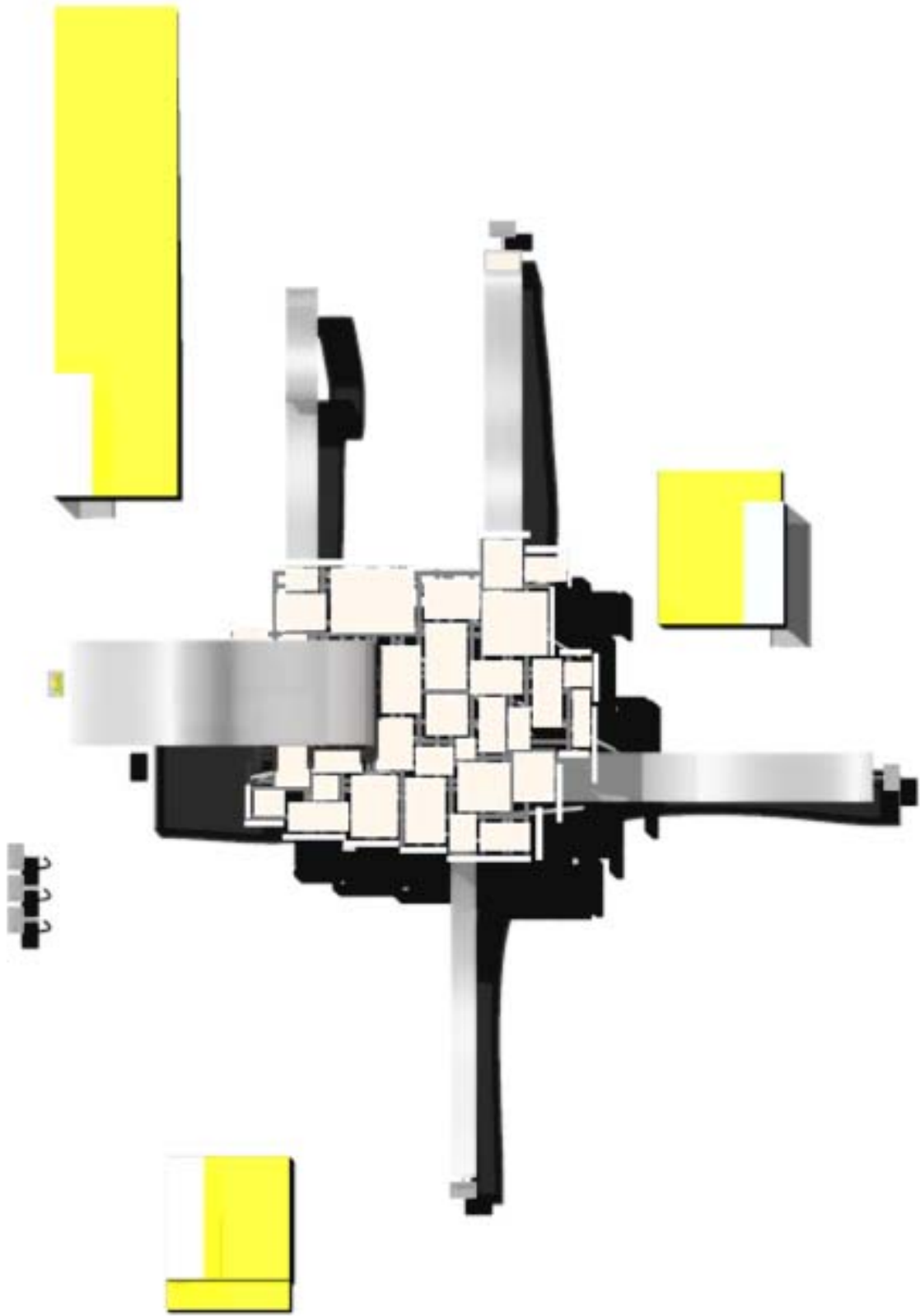

INFA plan - [approach entry from the east]



DEFEND OUR FREEDOM PROTECT OUR RIGHTS



Speaking out for freedom of speech

Calls to reform defamation laws are welcome, but change must be approached with caution.

FREE Speech Victoria, a coalition of lawyers, journalists and representatives of community groups, recently held a public meeting to discuss their proposed reforms to the state's defamation laws. The group believes that the law as it stands is an archaic impediment to free speech, in the community and in the press, and therefore to the robust workings of our democracy. It has proposed that four freedoms be established in the law — the freedom to speak about corporations; the freedom to speak on matters of public interest; the freedom to speak about the performance of public officers; and the freedom to speak without fear of unspecified damages. The Age has long supported calls to reform our defamation laws and therefore welcomes efforts to propel this important debate forward. However, any reforms must be tempered with an understanding that a change to the law carries the risk of unintended consequences. For example, the group proposes that "no corporation shall be entitled to sue for any cause of action in defamation, and no person shall be entitled to sue for any cause of action in defamation in reliance on any imputation arising from any statement made about a corporation." The proposal arises from understandable concern that corporations, with their deep pockets and legal departments, are using defamation laws to silence community groups that dare to criticise their actions. It is deeply regrettable that the law, as it stands, can be used in this way (although the corporation must prove that it has been financially damaged by what has been said about it). However, moves to strip corporations from taking any defamation action may prove to be unfairly restrictive — what to stop one company from making false and damaging claims about another if the law is removed? The Age supports the proposal that alternatives be made to unspecified damages to redress defamation when it does occur. At present, courts do not have the power to order that retractions or apologies be printed or broadcast to correct a defamation, they are only able to award money. However, Free Speech Victoria's proposal, that "no general damages shall be awarded for defamation, and no award of general damages shall be made for defamation if the plaintiff has not proved special damages." A more specific emphasis on the use of all words to be defamed. The best use of all words so that different plaintiffs can be exploited in a particular case. It is hoped that Free Speech Victoria's proposals have helped to move the debate forward.



DEMOCRACY

WE DELIVER



Images of the Civil Rights Movement



REFORM

Why, After 60 Years, Are We Still Fighting For Our Bill of Rights?

they fought for **DEMOCRACY**
now they want **JOBS**



FREE SPEECH AREA

THIS AREA HAS BEEN SET ASIDE FOR NON-PROFIT GROUPS TO DISPLAY THEIR CONSTITUTIONAL OR ENVIRONMENTAL FREE SPEECH DISPLAYS. THE COST OF DISPLAYS IS PAID BY THE CHAIRMAN OR CHAIRWOMAN. THIS DISPLAY OF PRODUCTS MUST BE IN COMPLIANCE WITH THE CITY OF LINCOLN AND THE CITY CHAIRMAN OR CHAIRWOMAN SUPPORT IN ANY WAY THE DISPLAY OR DISPLAYS OF PRODUCTS EXCEPTING COMMERCIALS.

Article v

Article vi

Article vii

done



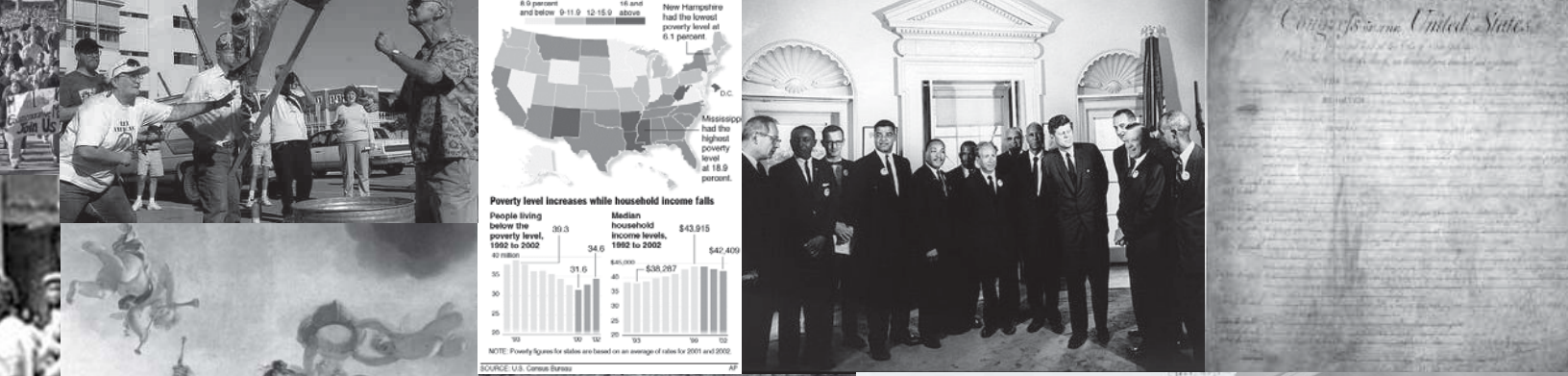

Poverty level increases while household income falls



NOTE: Poverty figures for states are based on an average of values for 2001 and 2002. SOURCE: U.S. Census Bureau



Constitution of the United States
 Proposed and adopted by the Congress, the first in the History of the world in the original and unaltered form.

Monticello Aug. 18. 93
 Your favor of the 21st is just now received. The letter to the Editors was written by me, and the only recommendation by the Editor of my fellow citizens is a book which I considered not containing more genuine doctrine on the subject of liberty than any other of high reputation since the adoption of our Constitution as confined to the legal thought and still think the Congress as plain and intelligible as I can make it. But when we see inspired writings made to speak what is not in the Constitution with them to say we cannot understand except to find language incapable of popular distortion, my impression is somewhat more reserved. They should look to the book with some opinion. It is not for to convince if the book established that a state has no right to tax the moral property within its limits, unless it can be called, as a report, in the bar of the Federal judiciary, then I may infer that these are my opinions, if no such doctrine is in them, my letter does not authorize their imputation to me.



DISSENT
 Protects
 Democracy



Bill of Rights
 Congress of the United States
 Proposed and held at the City of New York on Wednesday the fourth of September, on the second year of the first Congress.

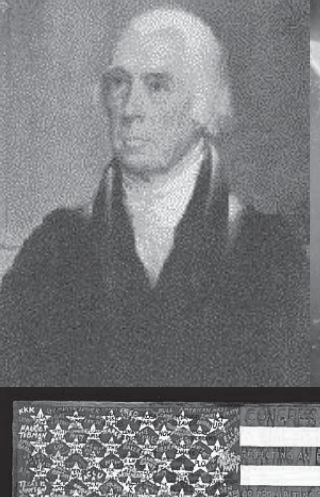

STATE THE TOPEKA JOURNAL
 Home Edition
 Turnpike Bonds
SCHOOL SEGREGATION BANNED
 Supreme Court Refutes Doctrine of Separate but Equal Education
 High Tribunal Finds to Specify When Practice of Dual Schools Must Be Disregarded by States

CONSTITUTIONAL REQUIREMENT OF EQUAL REPRESENTATION IN THE SENATE
 OBSCURING THE FREEDOM OF SPEECH



Photo courtesy of Kansas State Historical Society.

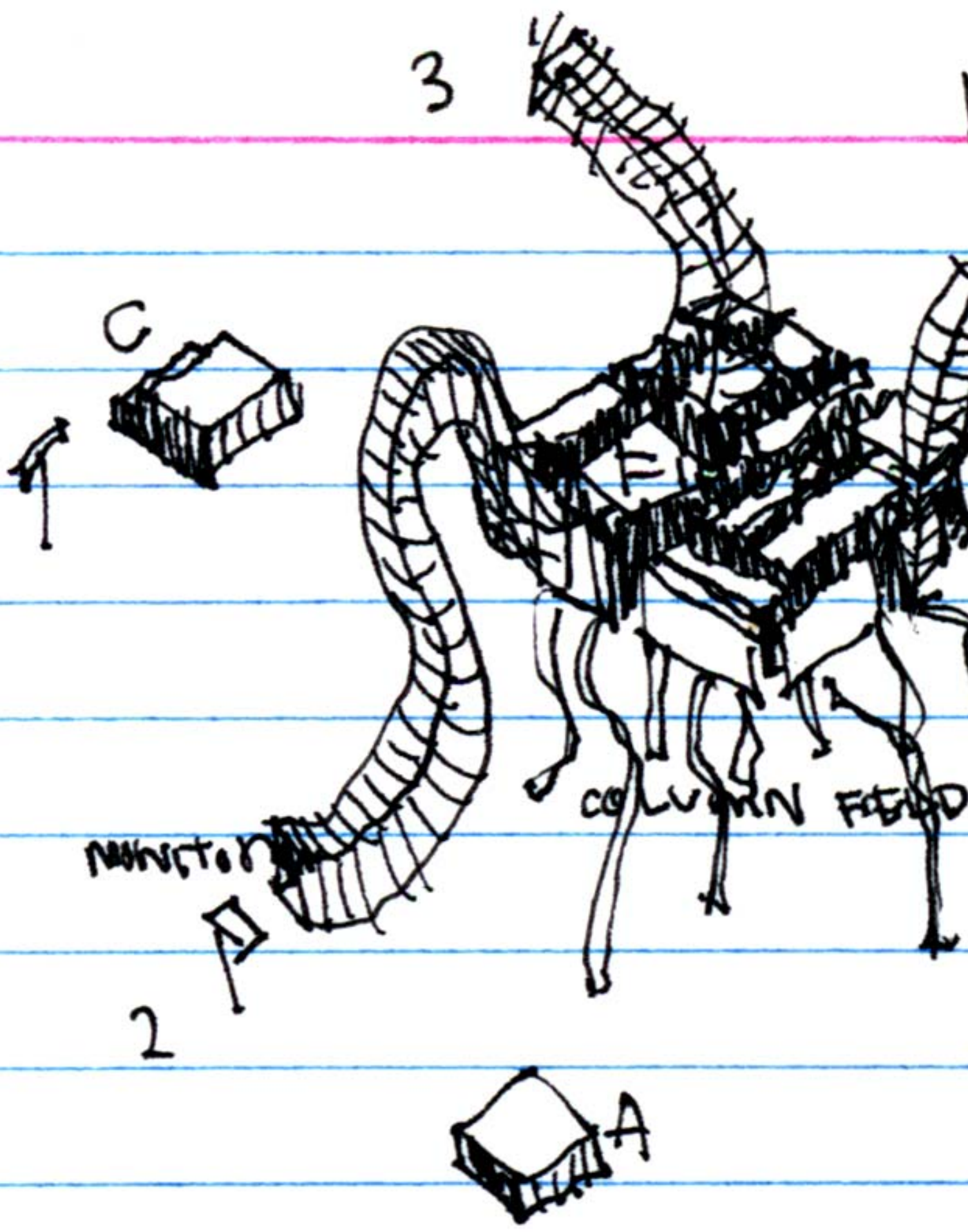

NFA

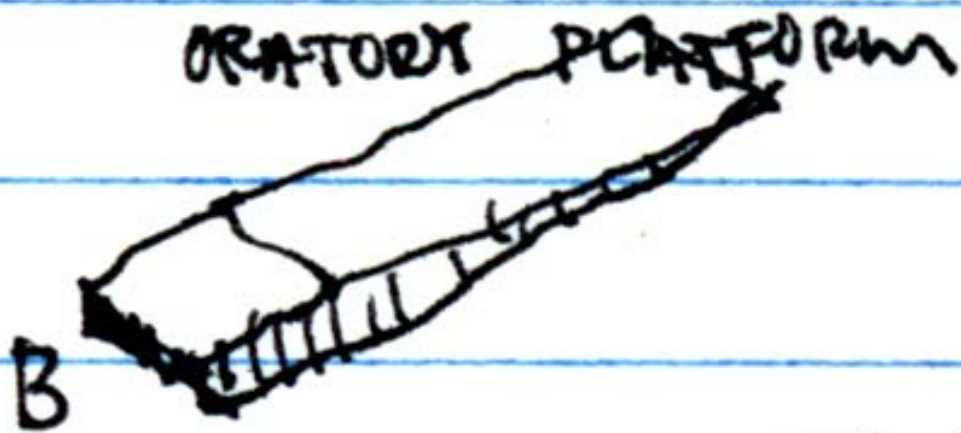

01.06

INFORMATION

FIELD

IMAGE

APP-

IMAGE

IMAGE

IMAGE

...

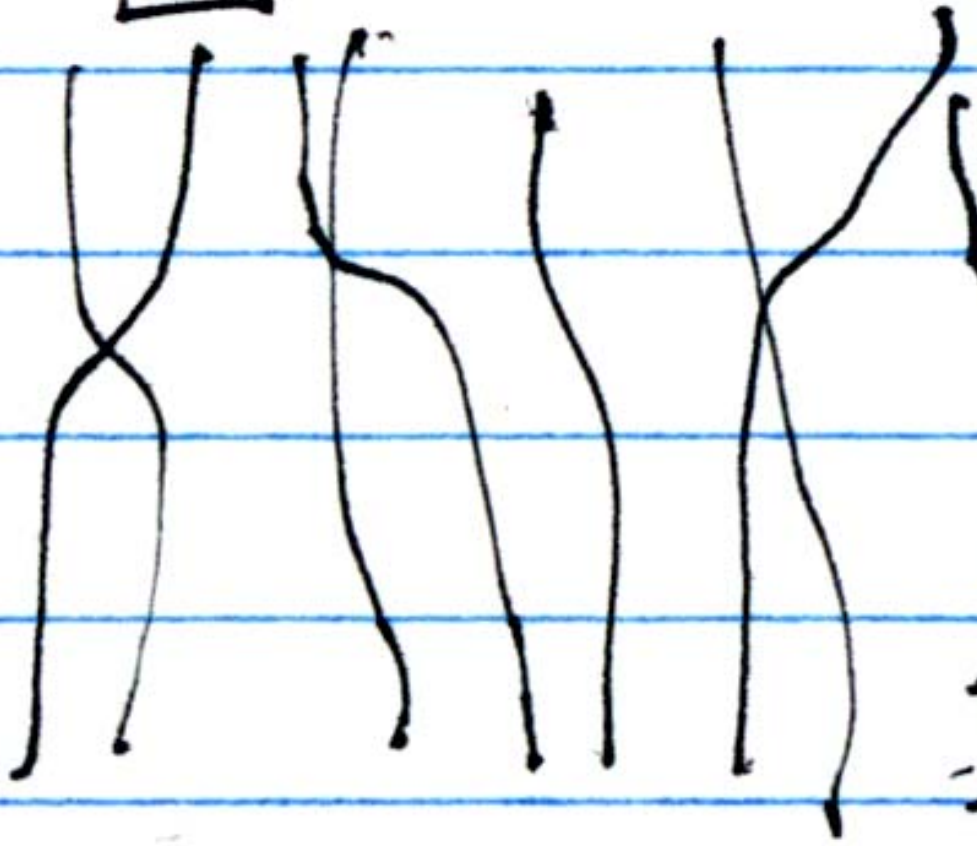

INFA

13

1

1

1

5

Access

Access

Access

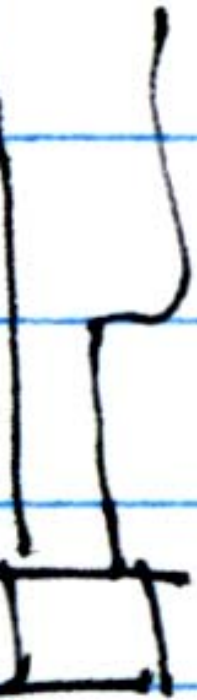

Access

CONNECTION

IMAGE

KEY BOARD

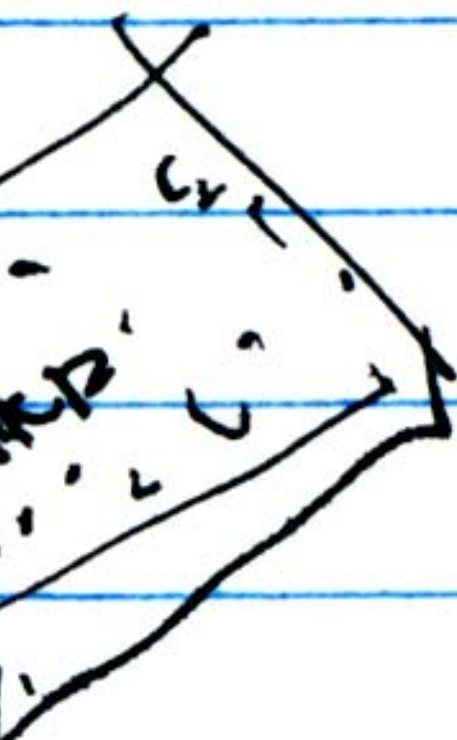

ACCESS

(NTP)

=

]

oo

]

os

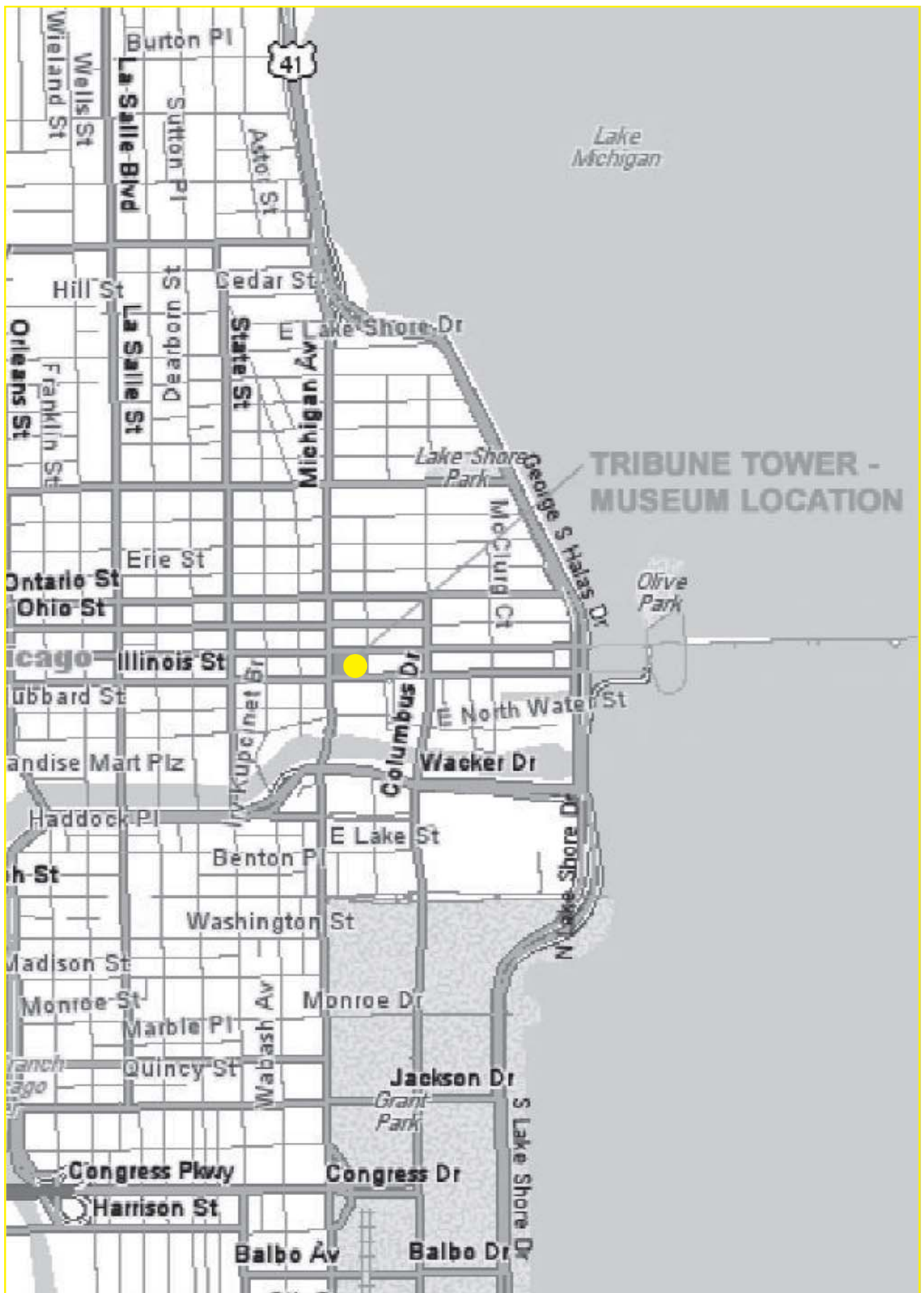

INFA site plan

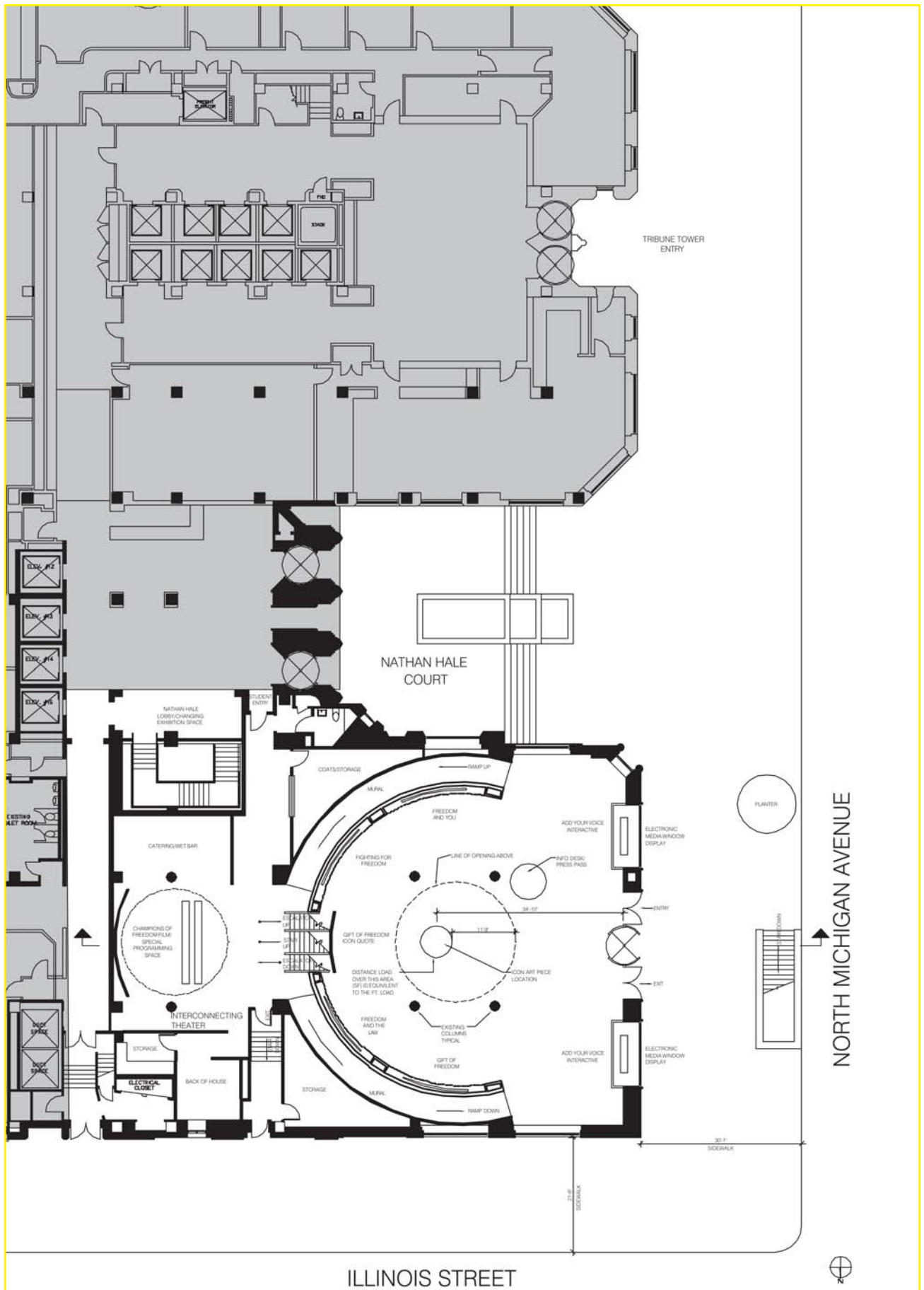

ILLINOIS STREET

INFA site plan - existing envelope

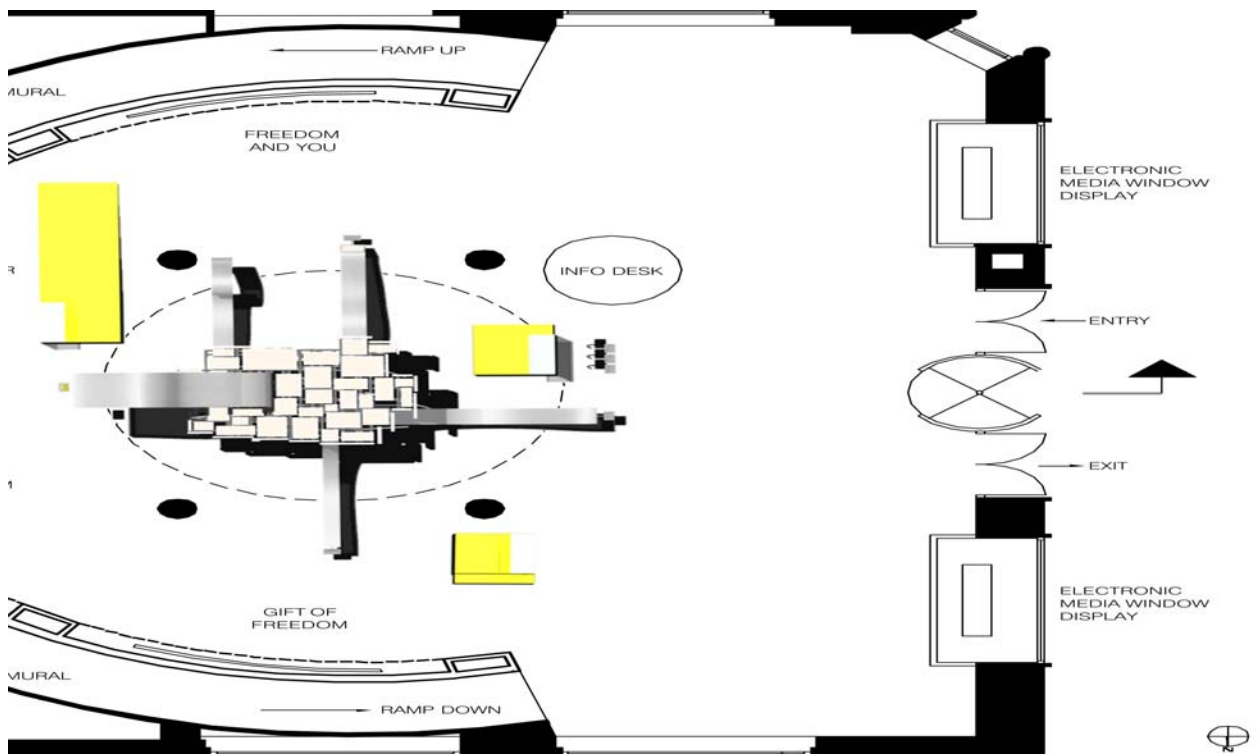

INFA plan - mccormick museum at chicago tribune tower

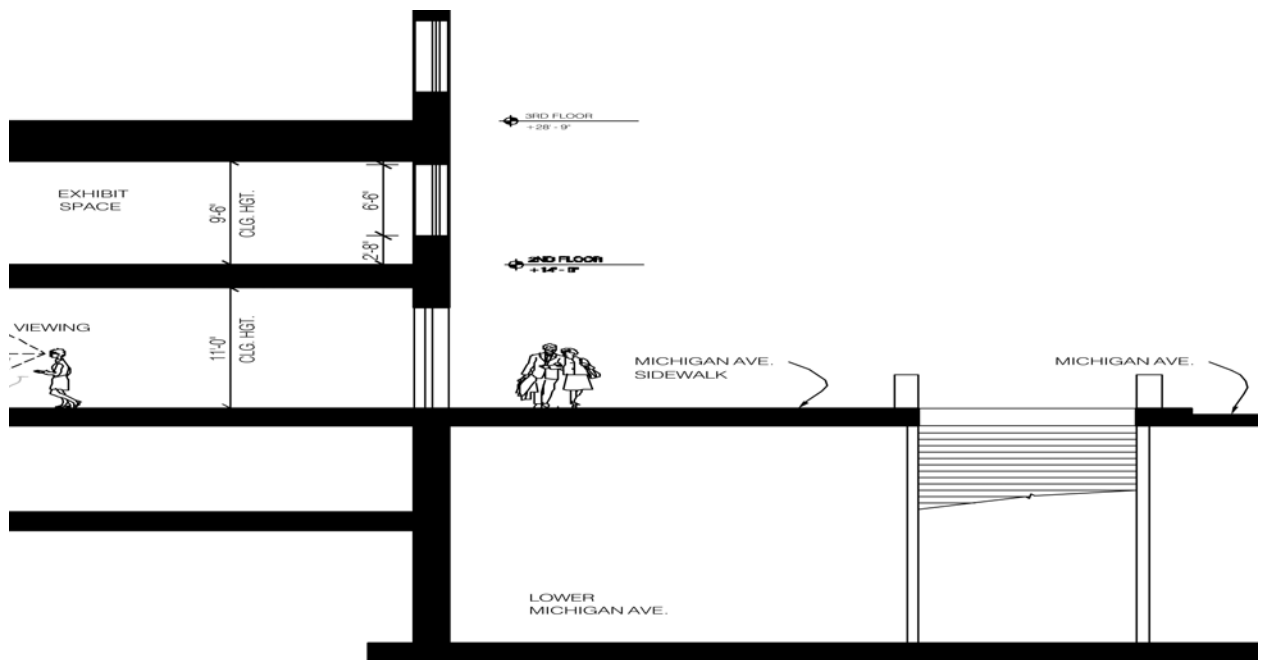

longitudinal section of **INFA** at entry

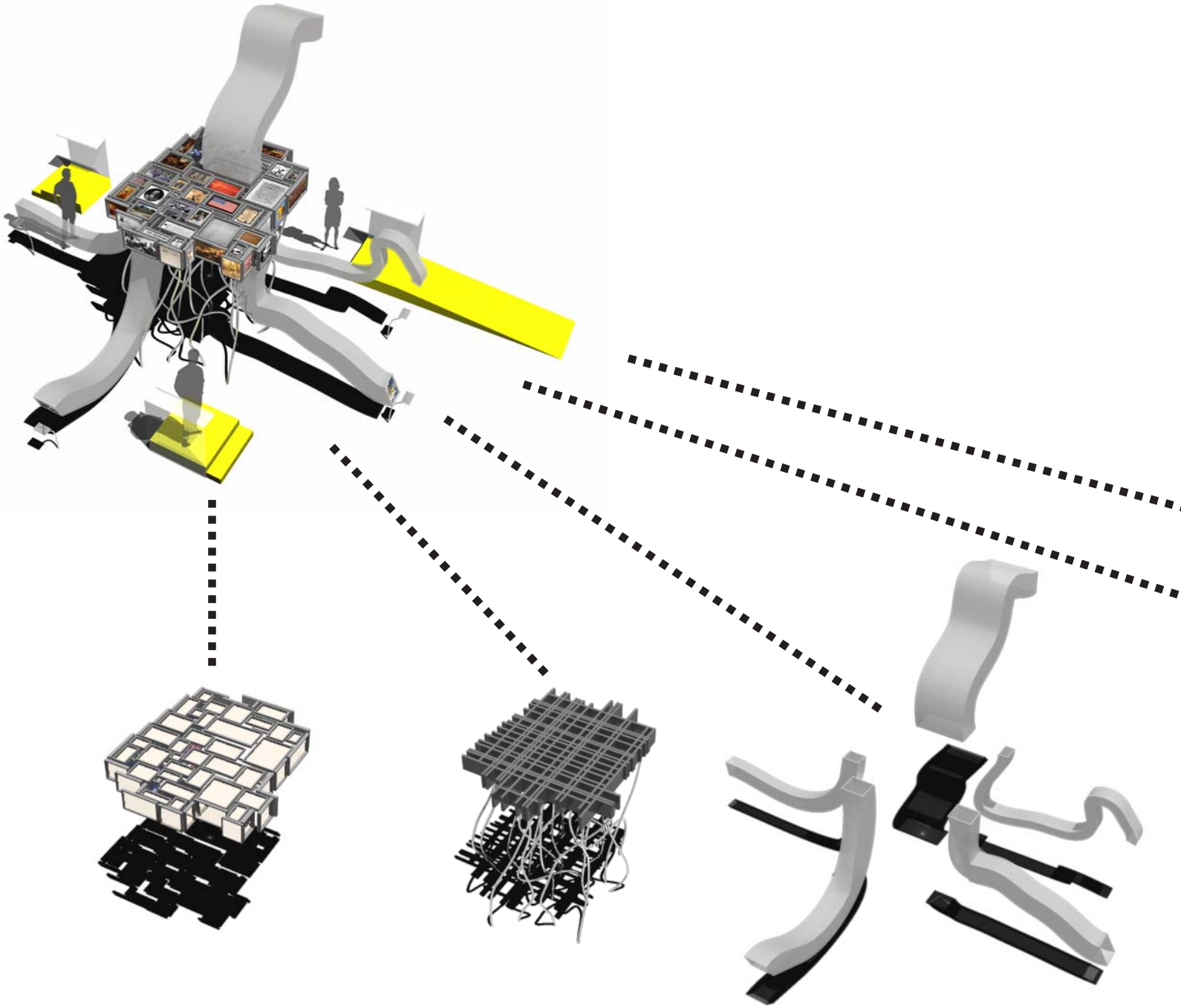

monitor field

structural cage

translucent tendrils

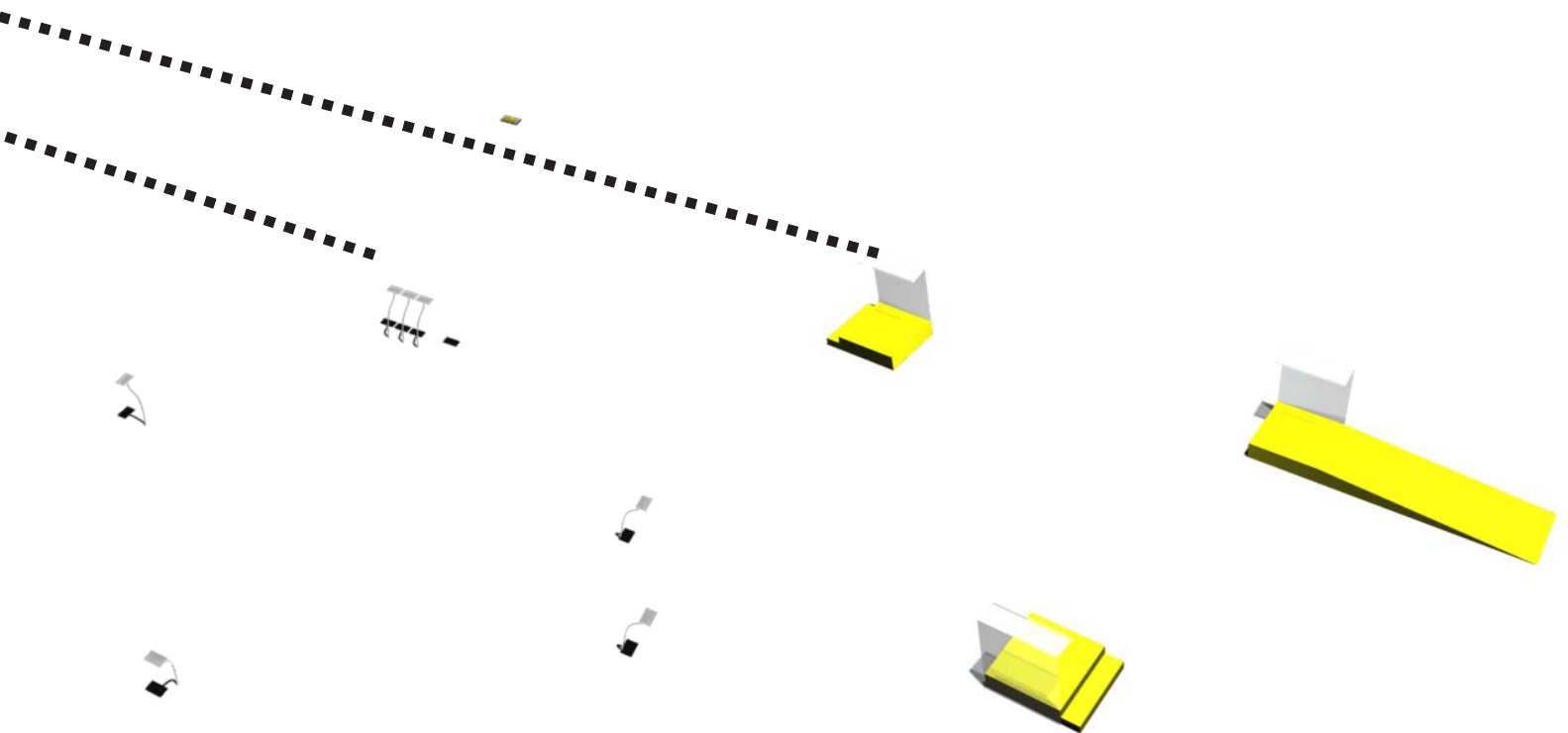

personal interfaces

oratory platforms

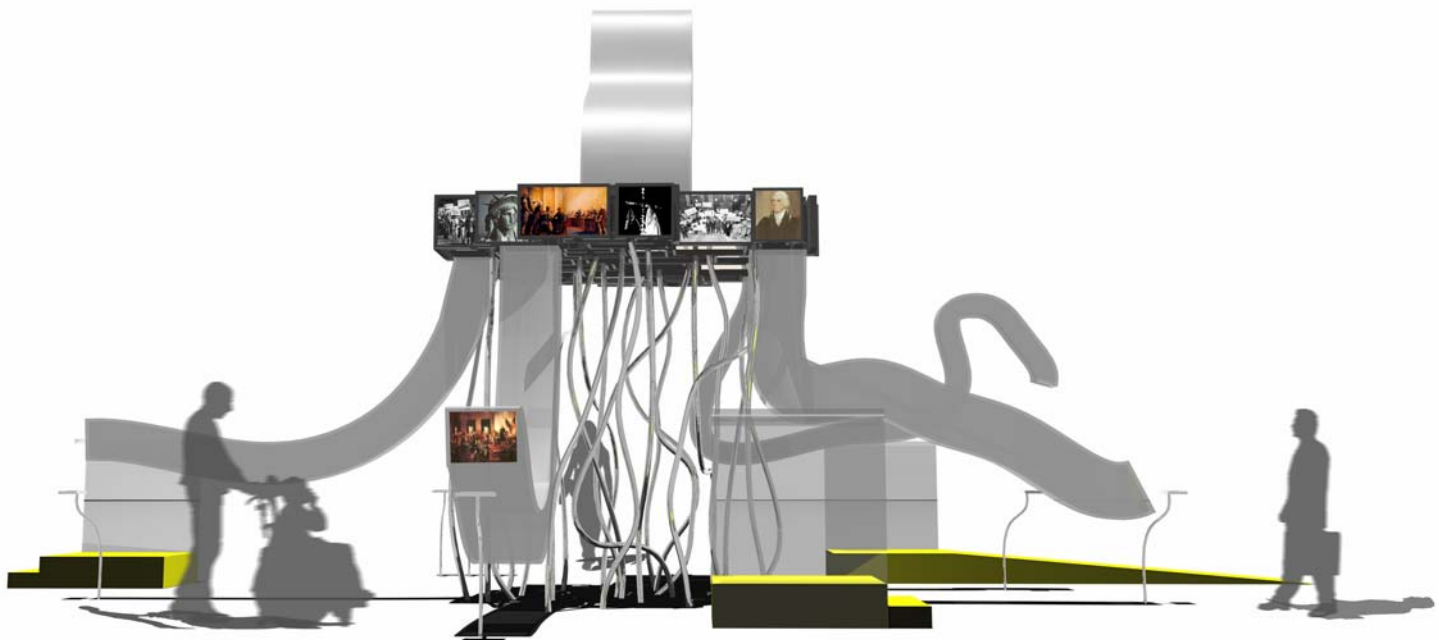

INFA entry approach (west face)

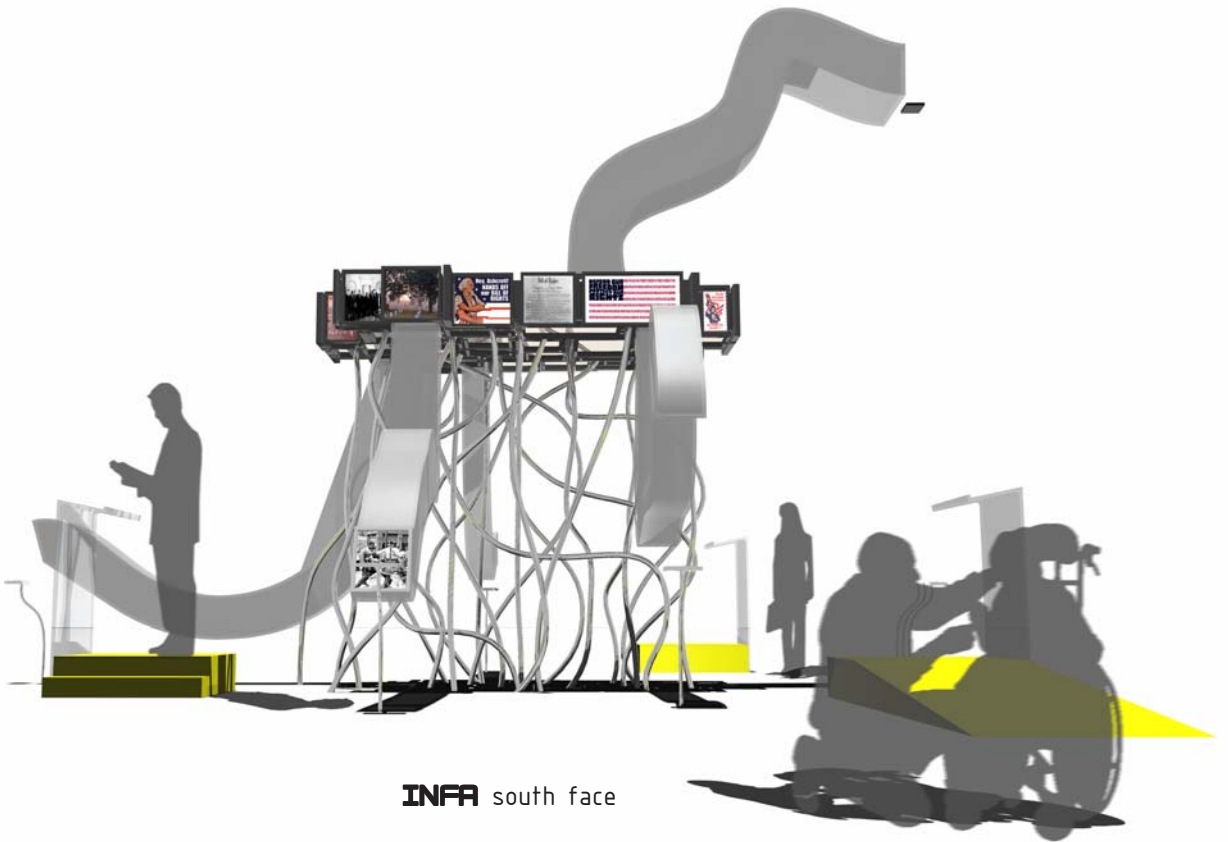

INFA south face

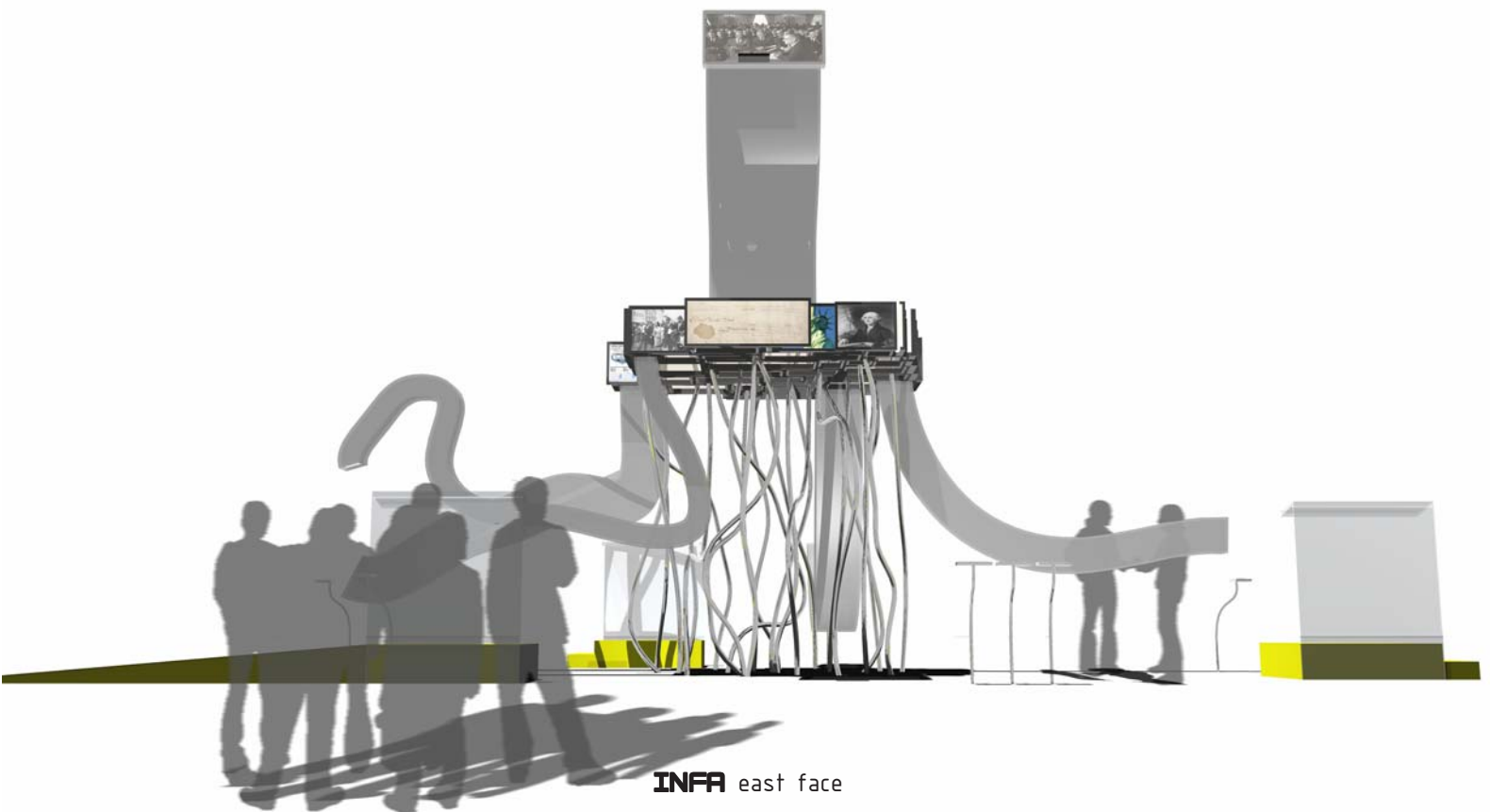

INFA east face

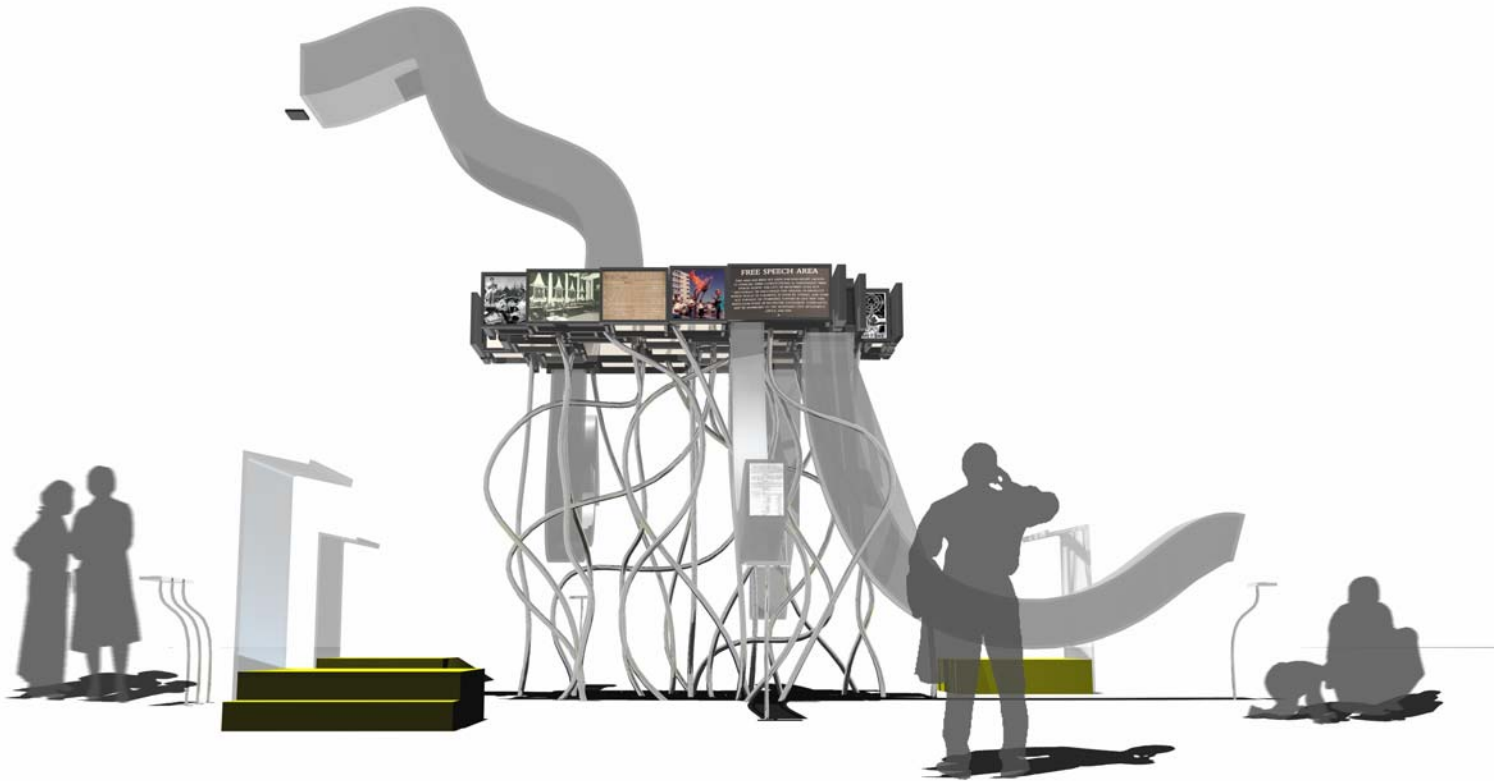

INFA north face

First Amendment

IN[formational] FA[cilitator]
monument to the first amendment